

600HF Hi-Flow Thruster

Product Guide and Warranty



Hi-Flow Thruster Warranty

CrustCrawler has a strong commitment to the high quality production of its HI-FLOW THRUSTERS and to provide industry leading after-sales support for our customers. Every HI-FLOW THRUSTER (GOODS) is fully covered by a comprehensive warranty to the original owner (OWNER) against defects in materials or workmanship for a period of 6 months from the date of shipment, whether or not use starts from that date. All claims under this limited warranty shall be deemed waived unless received by CrustCrawler within 10 days of delivery if visibly damaged or defective, and, otherwise, within 30 days after the defect to which each claim relates is discovered. This is not an unconditional guarantee against all hazards or failures and the Limitations and Exclusions listed below apply.

THIS WARRANTY IS EXPRESSLY IN LIEU OF ANY OTHER WARRANTIES EXPRESSED OR IMPLIED, INCLUDING ANY IMPLIED WARRANTY OF MERCHANTABILITY OR FITNESS.

This warranty is extended to the original OWNER of the GOODS and is not transferable. This warranty is limited solely to the repair or replacement, at our factory, of the defective GOODS. CrustCrawler shall not be liable for any damage or harm, nor for any exemplary, special, punitive, consequential or incidental damages, including but not limited to any loss of revenue, profit or use resulting thereby. If a component is found to be defective during the period of this warranty, CrustCrawler reserves the right to repair or replace the defective component or to refund the original purchase price at its own discretion. In no event shall CrustCrawler be liable for more than the original purchase price of the defective GOODS.

Limitations and Exclusions

This limited warranty does not cover:

- Damage caused by improper use, improper maintenance, incorrect reassembly or accidental damage
- Items subject to normal wear including but not limited to surface finish, seals, motors and cables unless found to be defective in workmanship or materials
- Modification made to the HI-FLOW THRUSTER without prior authorization from CrustCrawler Inc
- Damage due to incorrect power connection as described in the User's Manual
- Damage or failure that is caused by acts of God, acts of war, or other such similar or dissimilar occurrences beyond CrustCrawler's control.

Shipping and Return Material Authorization (RMA) Forms

Immediately upon identifying a problem which you believe to be subject to this limited warranty, you must request warranty service by contacting CrustCrawler. All requests for warranty service must be authorized by CrustCrawler prior to return of the GOODS. You must first attempt to work with our technical support staff to help diagnose the problem. This may include performing routine diagnostic procedures. The technician can determine if the problem can be resolved over the telephone or if return for repair is required. Upon determining that the product may be defective under the terms of the limited warranty, and that return to the repair facility is required, CrustCrawler will issue an RMA number which you must complete and return to CrustCrawler. Upon receipt of the RMA number, the GOODS can then be shipped to CrustCrawler for evaluation.

Do not return the GOODS to CrustCrawler prior to the receipt of the RMA number. The GOODS must be shipped in their original shipping containers and packing material or otherwise adequately packed for shipment, and the RMA number must appear clearly on the outside of the package. If the product is damaged during shipment or received in inadequate packaging, this warranty may not apply.

For warranty shipping, the OWNER is responsible for shipment of all GOODS to CrustCrawler and CrustCrawler will cover the costs of return shipment of GOODS to the OWNER up to \$90.00 USD maximum.

In all cases the OWNER is liable for damage to the GOODS that may occur during shipment and should consider insuring the shipment both to and from CrustCrawler.

CrustCrawler “High Flow” 600HF UROV Thruster Technical Specifications

CrustCrawler’s “High Flow” UROV thrusters were designed to be extremely powerful and customizable for any number of our customers unique UROV / ROV requirements. No other thruster on the market has the programmable flexibility to set specific operating parameters for different environmental conditions than the CrustCrawler “High Flow” series. Machined from top of the line materials and sealed with a custom designed fluoropoly spring jacket seal, these thrusters are powerful and engineered for powerful thrust capability in a small package.

Motor Specifications

- Motor Type – High efficiency brushless
- Weight – 274g. (9.7oz)
- Max Power – 600W
- Gear Ratio – 4.28:1
- Shaft Diameter – 5.0mm(.1969”)
- Maximum Case Temperature – 100C (212F)
- Operating Voltage – 12 to 50 volts

Connector Specifications

- Depth Rating – 10,000 ft.
- 4 prong
- Type- Sea-Con

Thruster Housing / End Caps

- T- 6 Aluminum

Thruster Seal

- Shaft Seal – Custom Lip Seal followed by encapsulating grease gallery

Finish

- Type III Hard Anodized Finish

Propeller

- Size – 2.36” (60mm) - 4 blade
- Material – Solid Brass
- Propeller Adapter – Aluminum

Kort Nozzle Adaptor

- Material – Aluminum with welded joints for strength
- Offset - 120 degrees

Depth Rating

- 3,000 feet – Oil Compensated

Thruster Weight

- Weight in air – 2 pounds (.907kg)
- Weight in water – 1 pound (.453kg)

Thrust Rating

- 50 volts – 15 pounds of thrust max (7.27kg)
- 12 Volts – 8 pounds of thrust max (3.63kg)

- **Note #1** - For 50 volt users, do not exceed the 15 pound thrust rating or damage to the thruster may occur!

- **Note# 2** - Never Exceed the / 15 lbs. of thrust (voltage X current) rating of the thruster or damage to the thruster may occur. **Always monitor your current consumption based on 12v, 25v and 50v**

A Note about Throttle Settings and Maximum Power of the Thruster

Whatever throttle you choose to use (computer, joystick etc.) with the 600HF Hi-flow Thruster it is important to note the following:

1. Once you complete the calibration routine of the throttle device you are using with the ESC's it is important to note that your full throttle settings **DO NOT DIRECTLY** relate to the maximum operational range of the thruster!

 2. In order to determine the maximum physical setting that you can move your throttle to without exceeding the thrusters power rating of the 600HF thruster, you will have to monitor your thrust / current consumption and note the maximum throttle setting.
- The 600HF thrusters are oil cooled to keep the thruster motor running cool within its operating thrust range. The 600HF thruster is designed to run with a burst thrust of 8 to 15 pounds of thrust maximum for short periods of time (1 minute maximum recommended). As a general rule, always ensure that you do not overheat the thruster when running the thruster for long periods of time. (see the "600HF Thrust vs. Current Rating" for more information)

Dimensions

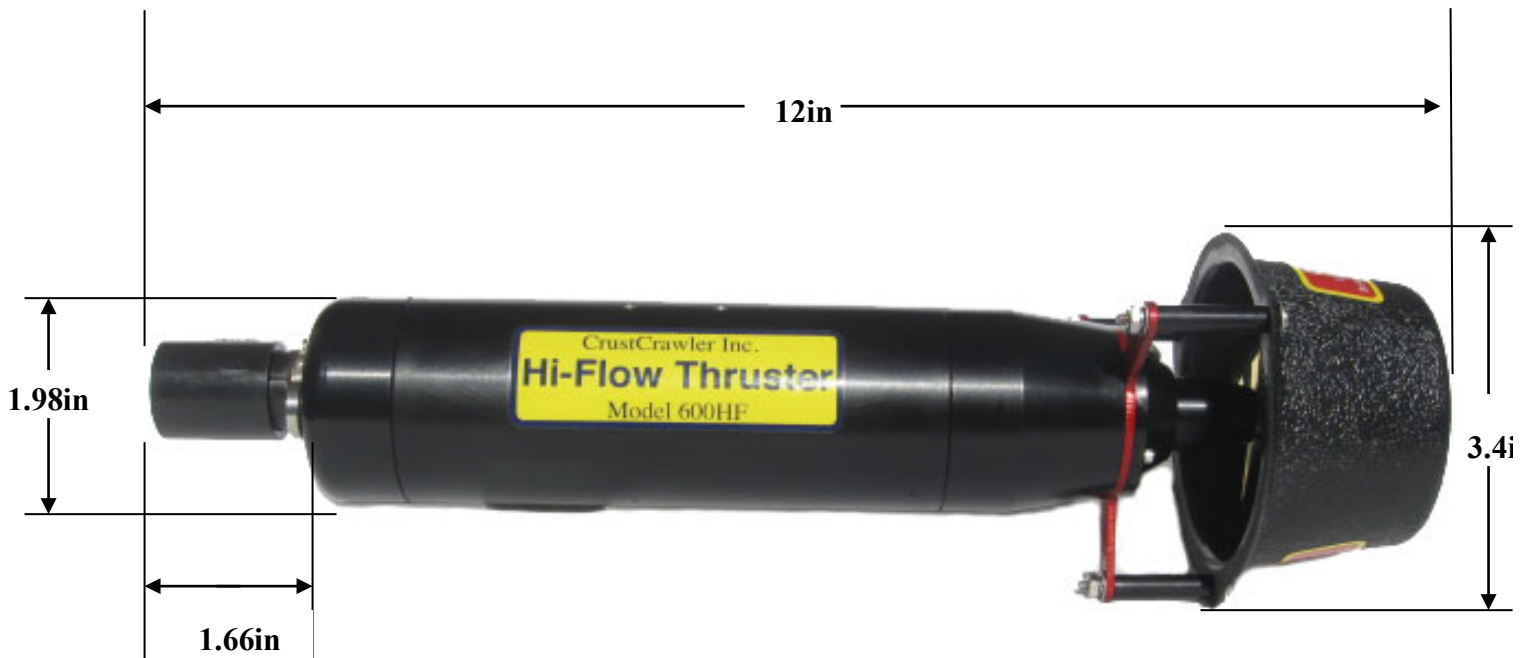

- Kort Nozzle Inlet – 2.80” (71mm)
- Kort Nozzle Outlet – 2.44” (62mm)

Safety

- Always unplug the Hi-Flow thruster before handling the propeller in any way.
- Always practice safe electrical handling and safety practices when working around water.

Break-In Period

The Hi-Flow thruster can be run at any speed right out of the box fully submersed. However, do not run the Hi-Flow thruster out of the water at high speeds for longer than 30 to 60 seconds or overheating and possible damage can occur.

Thruster Control

Any brushless motor control software / hardware can be used to operate the Hi-Flow thrusters. CrustCrawler offers a specifically engineered Phoenix ESC controller from Castle Creations which has special firmware developed especially for the Crustcrawler series of ROV thrusters. The firmware includes:

- Soft start capability for slow rotation speeds
- Forward and reverse throttle amount percentages
- Programmable throttle curves for different water conditions

We have also have a suggested control diagram in this manual for thruster control as an option. However, thruster control is up to you our customer as there are many options to choose from.

Oil Compensating

The Hi-Flow thrusters use only Consumer grade 99.9% mineral oil for oil compensation. This can be found at any local pharmacy or drug store. DO NOT use any other type of oil for oil compensation purposes. Before operating the 600HF thruster, the thruster must be oil compensated.

1. To oil compensate a Hi-Flow thruster, simply remove the oil compensation plug using the supplied 3/16" allen wrench as shown in figure #1.



Figure 1 – Removing the Oil Compensation Plug

2. Stand the thruster up vertically onto its Kort Nozzle.
3. Hold a dry rag around the body of the thruster to catch any mineral oil you may spill.

4. Using a measuring cup with a pouring lip (or equivalent), slowly pour the mineral oil into the body of the thruster until the oil reaches the last thread at the bottom of the oil compensation plug. DO NOT fill the plug!
5. Let the thruster sit with the plug removed for 10 minutes to ensure most of the air bubbles percolated out of thruster.
6. Check the level of the mineral oil to ensure the level of the oil is at the last thread at the bottom of the oil compensation plug. Add mineral oil if required.
7. Screw the oil compensation plug back onto the thruster until hand tight. Tighten the oil compensation plug $\frac{1}{4}$ turn, once it is hand tight. NEVER OVERTIGHTEN THE OIL COMPENSATION PLUG OR YOU MAY STRIP THE THREADING OF THE HI-FLOW THRUSTER!
8. Run the Hi-Flow thruster for 20 – 30 seconds and recheck the level of the mineral oil. Fill only as required.

Note: The mineral oil should be changed after every 8- 10 cumulative hrs. of thruster use.

Connecting the 18” Sea-Con Cable

1. Before connecting the 18” Sea-Con cable, you must first **very lightly** lubricate the male prongs of the cable with pure silicon grease. **Failure to do so will result in damage to the female plug on the Hi-Flow thruster and void its warranty.** Each time the Hi-Flow thruster is used in the water or is reconnected, the male prongs must be lubricated. (**never over lubricate!**)



Figure 2 - Lubricate before connecting

2. Line up the 4 male prongs with the female connector on the Hi-Flow thruster. The silver, male prong is the guide prong and is used as a guide to connect the Sea-Con cable correctly to the female connector. (figure #3).

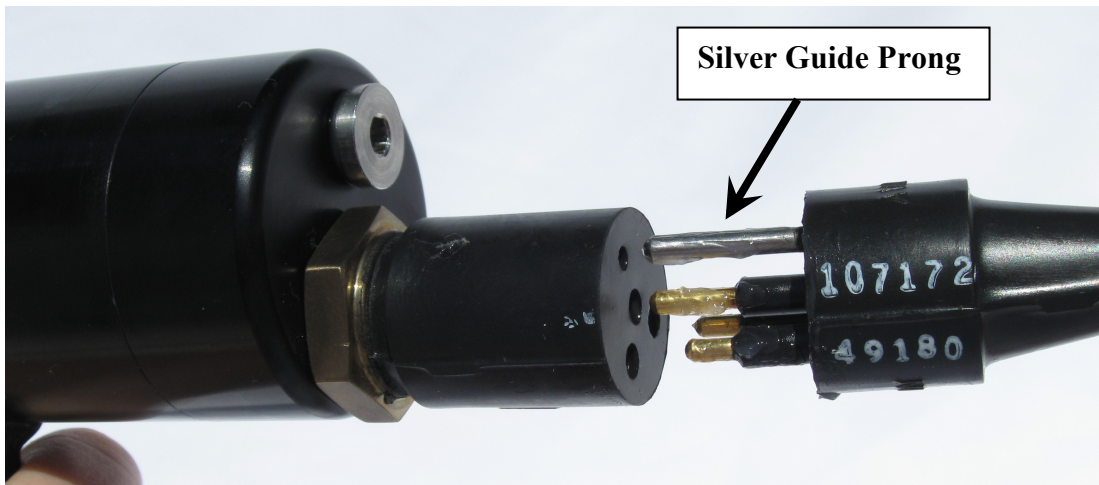

Figure 3 - Connecting the Sea-Con cable

3. Firmly press the cable into place until there is no space between the cable connection. (figure #4)



Figure 4 - Completed Connection

Connecting the Castle Creation Electronic Speed Controller (ESC) to the Hi-Flow Thruster

CrustCrawler has engineered a special UV resistant, potted and completely waterproof housing for the Castle Creations Phoenix ESC's. This design allows you to bolt the ESC directly to your UROV. All of the Hi-Flow thrusters have been internally wired the same way, so the diagrams shown on the subsequent pages will apply to any series of Hi-Flow thruster.



Figure 5 - ESC Controller (un-potted)

- The Phoenix ESC's uses Pulse Width Modulation (PWM) for brushless motor control (full forward - 2ms square wave, full reverse – 1ms square wave, neutral 1.5 ms square wave). Customization of throttle and brake curves along with forward and reverse characteristics can be programmed using the USB programming kit (optional). All Phoenix ESC are pre-programmed for both 100% forward and reverse throttle from Crustcrawler.
- Each motor will require (1) ESC. Do not attempt to connect and control (2) thrusters with (1) ESC.
- Any brushless speed controller with a rating of at least 20 amps with reverse capability can be used with the 600HF Thruster.

Best Practices

- Ensure that you provide a solid, soldered connection when connecting the ESC to the thruster. Also, when using the enclosed shrink tubing, ensure that the tubing is sealed on the inside and the outside to ensure a waterproof seal. (“Liquid Tape” or other liquid sealants that dry to a hard waterproof encasement will work).
- *Always use wires that are equal to or greater in thickness than the wires on the thruster and ESC!*
- The Phoenix ESC’s are not meant to propagate a signal through long lengths of wire. As a best practice, the Phoenix EDGE ESC’s should be within 1 to 10 feet of the thrusters (depending on wire size used). Longer lengths of wires can be used between the thrusters and the ESC’s but performance will have to be monitored.

- A Pololu Servo Controller can be used to attach each Phoenix ESC to a specified channel to control each thruster independently with either software, joystick control or both. A single PSC can control up to 18 thrusters.

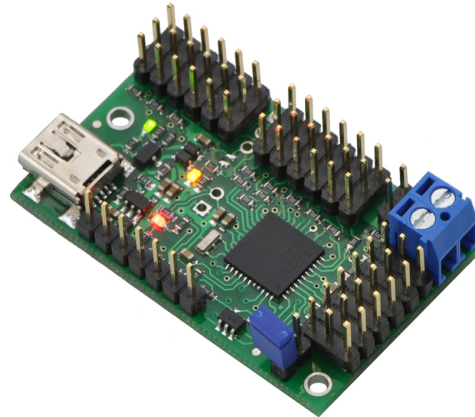
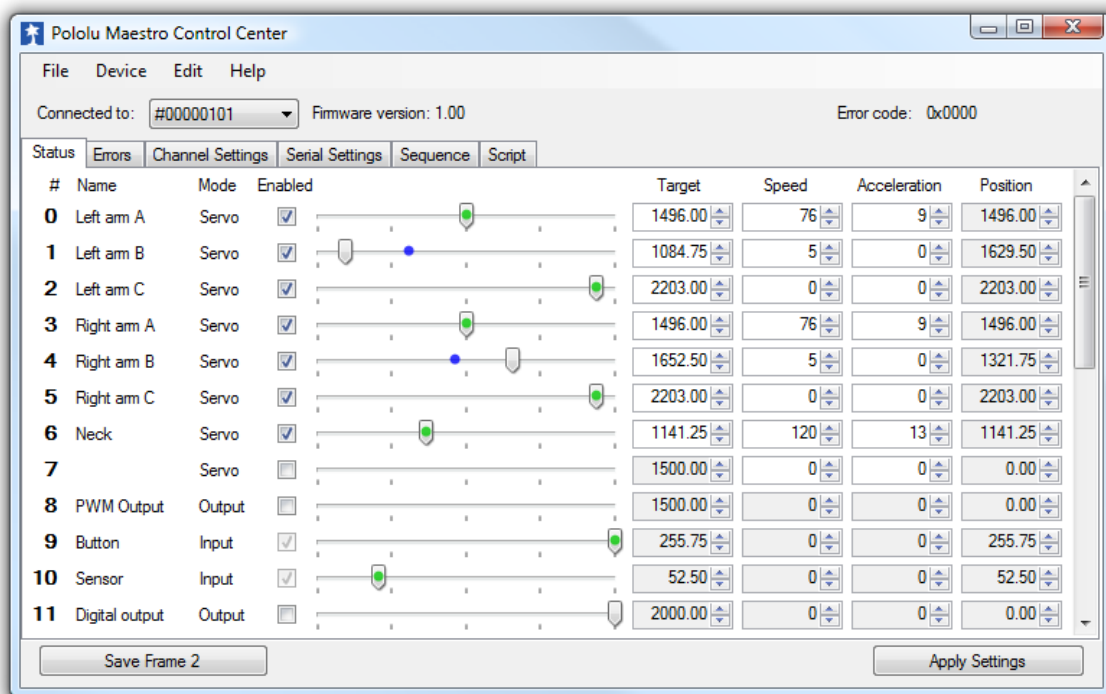

Figure 6 - Pololu Servo Controller

- The Pololu servo controller generates the PWM signals needed by the Phoenix brushless motor controllers for throttle control. The Pololu servo controllers software can be used as a throttle control for the thrusters using its powerful control software or connected to a microcontroller for throttle control.



- For more detailed information on the operating parameters and wiring characteristics of the Castle Creations Phoenix ESC's, be sure to read the enclosed documentation that came with your ESC.

Power / Signal Connection

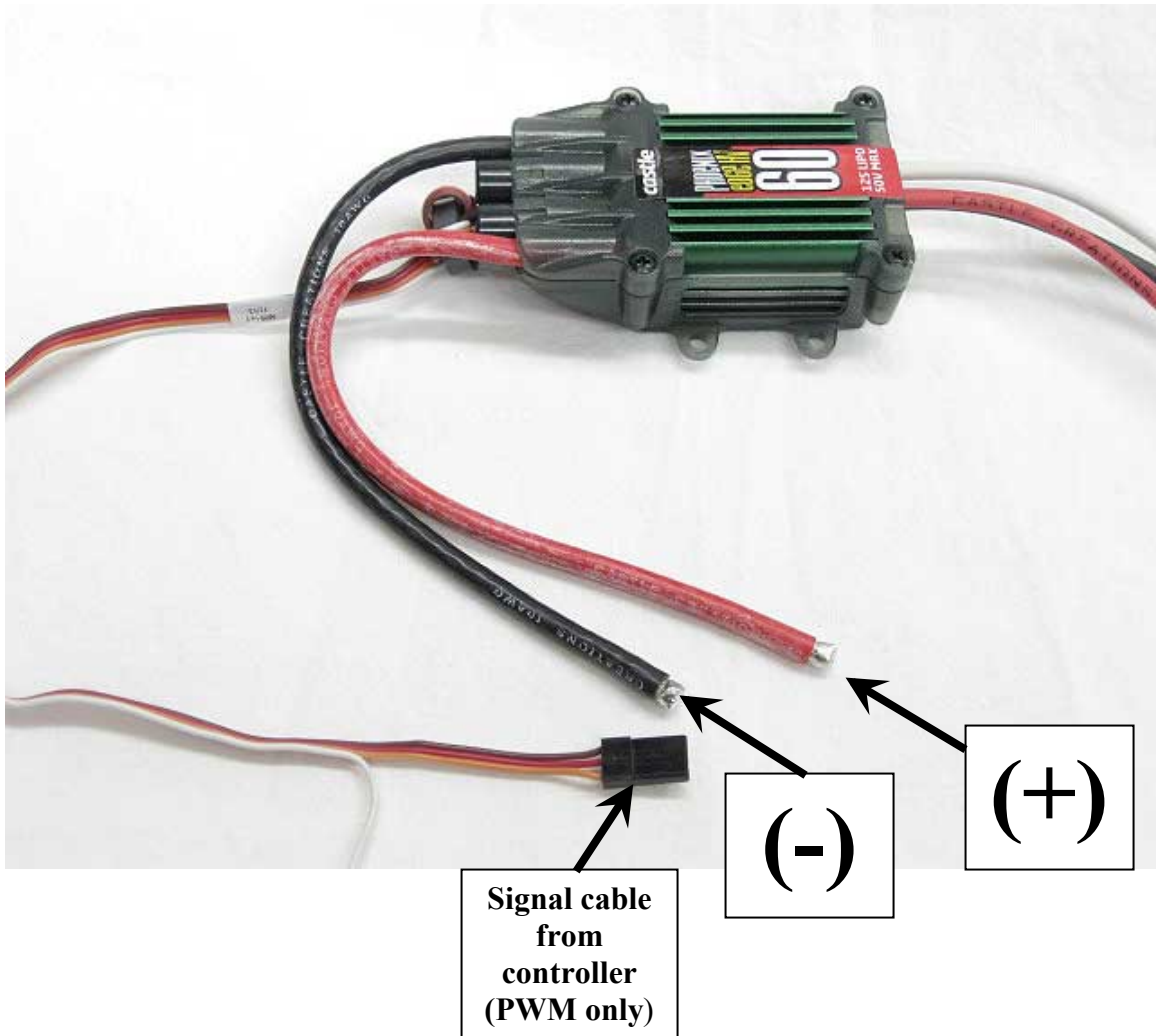

Note: Phoenix EDGE ESC's, require 5V on the brown(-) and red wires(+). The orange wire is for the PWM signal.

Hi-Flow Thruster Connection

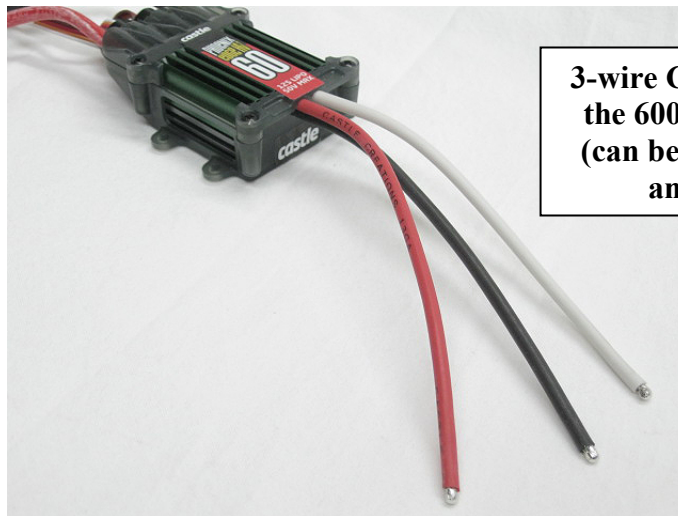

3-wire Connections to the 600HF Thruster (can be connected in any order)

Clockwise Rotation – Right Hand Thrusters

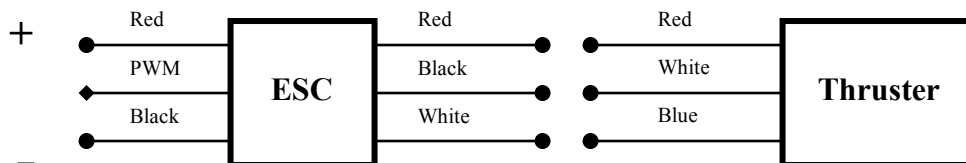

Counter-Clockwise Rotation – Left Hand Thrusters

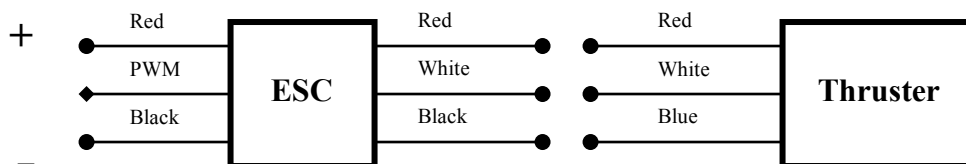

- **Note: See page 16 for more information on propeller and correct rotation information**

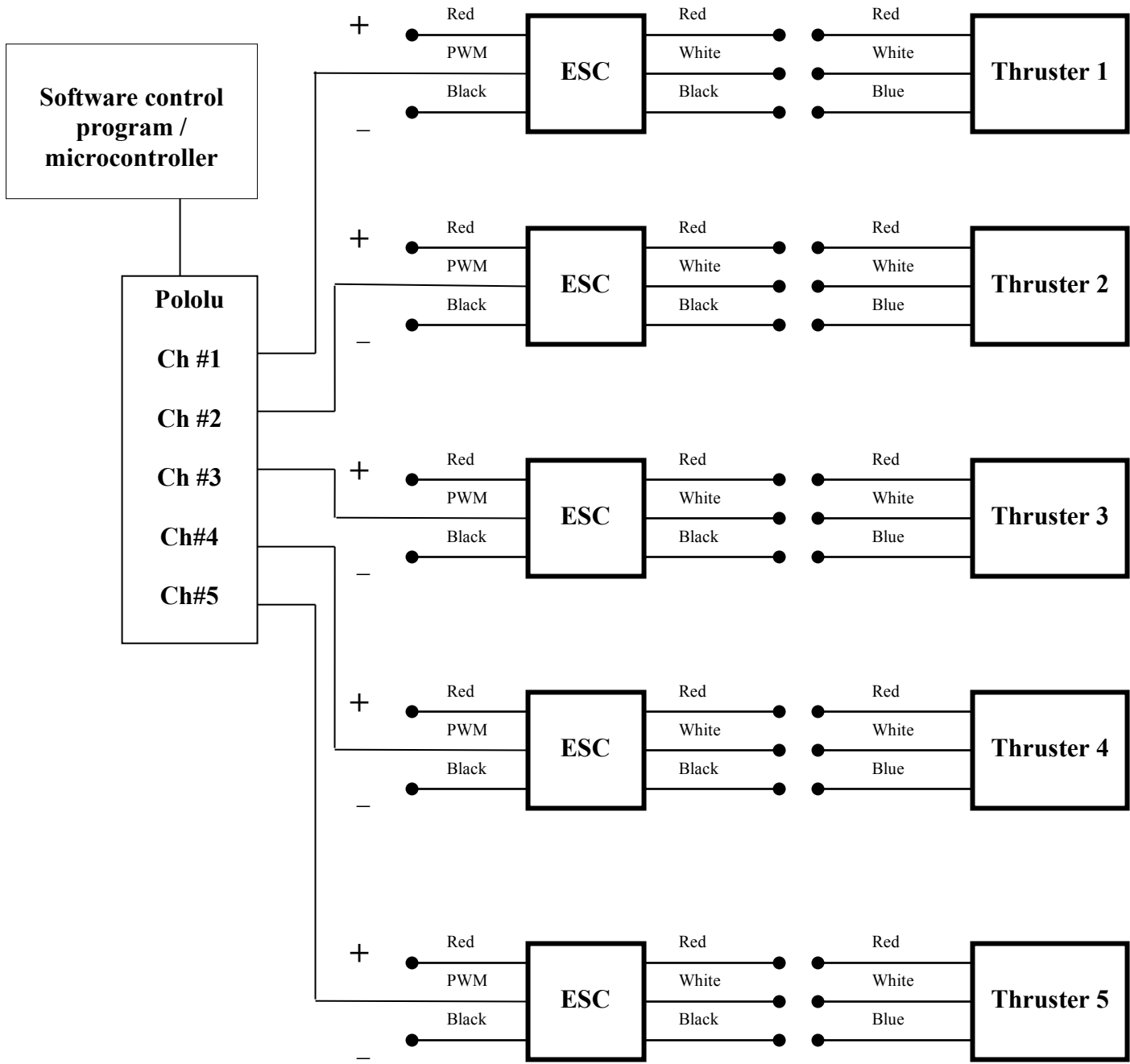

- The diagram above depicts an example of thruster control using a Castle creations Phoenix Electronic Speed Controller (ESC) and the Pololu Servo Controller (PSC). This is just one example of the many ways of which you can control the 600HF thruster.

Throttle Calibration of the Castle Creations Phoenix ESC

When the Castle Creations Phoenix ESC is first connected to the Hi-Flow 600HF thruster, the ESC must be calibrated to your throttle. The “throttle” used can take many forms but is not limited to:

- Software Throttles
- Joysticks
- Sliders

Once the ESC is calibrated to each thruster, there is no need to calibrate the ESC again unless you have changed to a different type of throttle.

Calibration Steps

The Phoenix manual has basic steps on how to calibrate the ESC to your throttle. We have summarized those steps below. Before proceeding with the steps below, ensure that your ESC is solidly connected (soldered and insulated) to your 600HF thruster and you have the proper power connections.

Step 1

With power off to your ESC , move your throttle to full forward throttle

Step 2

Turn on the power to your ESC . You will hear a series of short “beeps” followed by a steady series of beeps.

Step 3

Once there is a steady series of beeps, move your throttle to full reverse throttle. You will hear a series of short beeps followed by a steady series of beeps.

Step 4

Once there is a steady series of beeps, move your throttle to neutral or center. There will be a series of short beeps followed by silence. Your ESC is now calibrated to your throttle.

Caution! Always remember to ensure your throttle setting is in the neutral position when powering on your ESC. Failure to do so could result in the thruster running at the current throttle setting or the ESC going back into calibration mode.

A Note about Throttle Settings and Maximum Power of the Thruster

Whatever throttle you choose to use (computer, joystick etc.) with the 600HF Hi-flow Thruster it is important to note the following:

- Once you complete the calibration routine of the throttle device you are using with the Phoenix ESC's it is important to note that your full throttle settings **DO NOT DIRECTLY** relate to the operation range of the thruster (see the "600HF Thrust vs. Current Rating" for more information)
- In order to determine the maximum physical setting that you can move your throttle to without exceeding the thrusters operational range of the 600HF thruster, you will have to monitor your current consumption / thrust rating. (see the "600HF Thrust vs. Current Rating" for more information)
- Failure to do so may result in thermal damage to the 600HF thruster motor!

Right Hand / Left Hand Propeller Configurations

The Hi-Flow thrusters come with either a right hand or left hand propeller configuration. Right and left hand propellers are needed whenever (2) Hi-flow thrusters are mounted in a parallel (side by side) configuration from each another. With each propeller rotating in an opposite direction from each other, the opposite rotation will cancel out each thrusters torque resulting in the UROV body traveling in a straight line.

- For all other, single mount Hi-Flow thrusters that are mounted in your UROV, either left or right hand propellers configurations may be used.



**Clockwise Rotation
Hi-Flow Thruster –
Right Hand Propeller**

**Counterclockwise
Rotation
Hi-Flow Thruster –
Left Hand Propeller**

To determine the correct rotation of the propeller:

- If the curve of the propeller is on the **right sides** of the blades (above left) – Clockwise rotation = forward thrust
- If the curve of the propeller is on the **left sides** of the blades (above right) – Counterclockwise rotation = forward thrust

Important! Please Read!

Important Information about the proper operation and care of the 600HF Thruster

CrustCrawler's Hi-Flow series of thrusters are designed to be a rugged, affordable choice for all types of AUV/ROV applications. To ensure many hours of reliable use, the best practices listed below will ensure a long, service free life of the thruster motor and gearbox.

Operating Best Practices

- The gearbox in the 600HF thruster is built extremely strong but as a best practice abrupt and full speed thruster changes of rotation should be avoided.
- The 600HF thrusters are mineral oil cooled to keep the thruster motor running cool and to give it depth rating within its thrust operating range. The 600HF is designed to run with a burst thrust of up to 15 pounds of thrust maximum for short periods of time (40 – 60 seconds maximum recommended). As a general rule, always ensure that you do not overheat the thruster when running the units for long periods of time. (see the “600HF Thrust vs. Current Rating” for more information)
- If your thrusters were used in salt water, always rinse the entire thruster, especially the front of the motor and prop assembly with fresh water after each use.
- Change the mineral oil every 7hrs of continuous use. Failure to do so can lead to corrosion of the thruster motor and it's components.
- When tightening the kort nozzle screws, never over tighten these screws or you may damage the kort nozzle shroud (1/4” turn from finger tight).
- NEVER leave the thruster soaking in water when not in use.
- Always re-grease the grease gallery after every use. Failure to do so can leave water in the grease gallery which can lead to damaged thruster components.
- NEVER run the Hi-Flow thruster out of the water at full throttle. Always run the thruster out of the water (for testing etc) at 50% max of full throttle for no longer than 40 -60 seconds at a time.

- Ensure that you provide a solid, soldered connection when connecting the ESC to the thruster. Always use shrink tubing and a good sealant compound to ensure that each connection is sealed and waterproof (**“Liquid Tape” is an excellent, fast drying sealant that can be purchased at most hardware stores**).
- **Always ensure that water has been purged from the grease gallery of the thruster after each use and re-greased.**
- **Never exceed the thrust rating of the thruster of 15 pounds**
Always monitor your current rating vs. your throttle input when setting up and testing your thruster(s). This is especially true for 25 and 50 volt users.

A Note about Throttle Settings and Maximum Power of the Thruster

Whatever throttle you choose to use (computer, joystick etc.) with the 600HF Hi-flow Thruster it is important to note the following:

- Once you complete the calibration routine of the throttle device you are using with the Phoenix ESC’s it is important to note that your full throttle settings **DO NOT DIRECTLY** relate to the maximum power rating of the thruster!
- Failure to do so may result in thermal damage to the 600 thruster motor (see the “600HF Thrust vs. Current Rating” for more information)

Storage

- If you are going to store the thruster for long periods of time, it is a best practice to store the thruster vertically, kort nozzle downward and to completely drain the mineral oil from the thruster and re-fill it with fresh oil. Also, ensure that all water has been purged from the grease gallery and re-greased.

Applying Grease to the Grease Gallery

1. Remove the grease screw as shown in figure 1 (400HFS-L shown as an example).
2. Apply the white lithium grease using the supplied grease syringe until excess grease begins to emerge from between the prop adapter and grease gallery fitting.
3. Rotate the propeller 5 complete turns
4. Repeat steps 1 -2
5. Re-install the grease screw

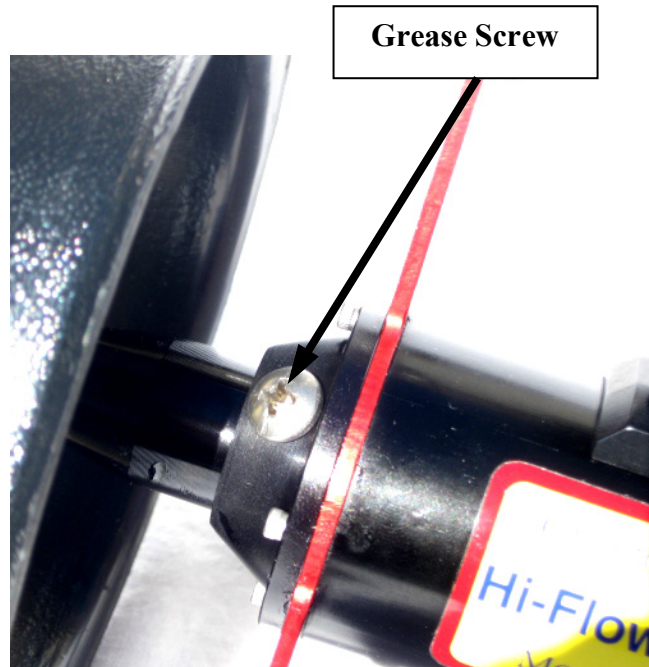

Figure 1 - Remove Grease Screw

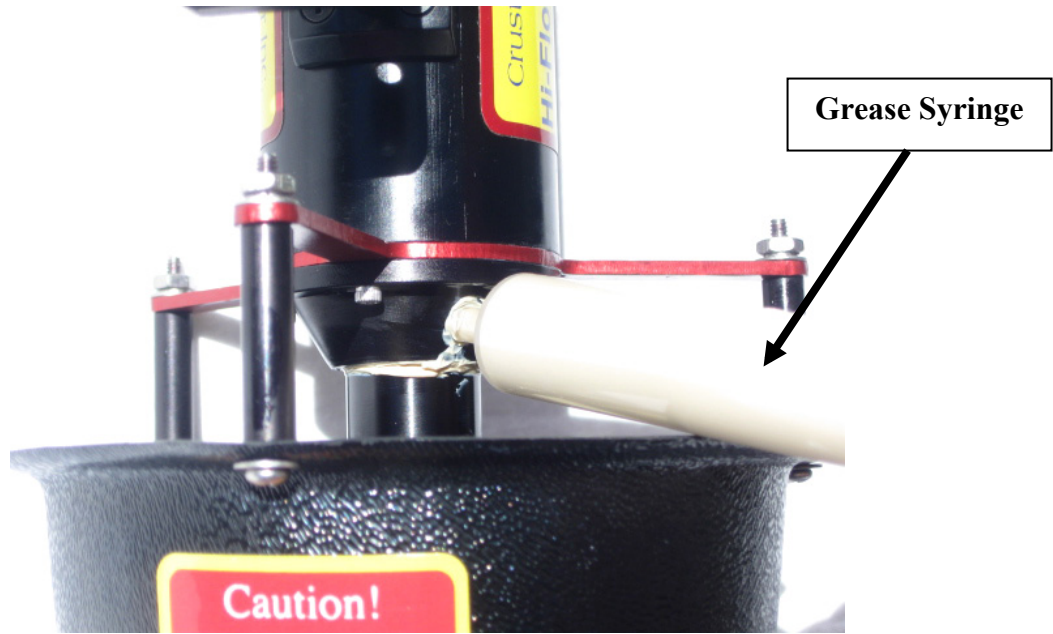

Figure 2 - Apply grease using grease syringe

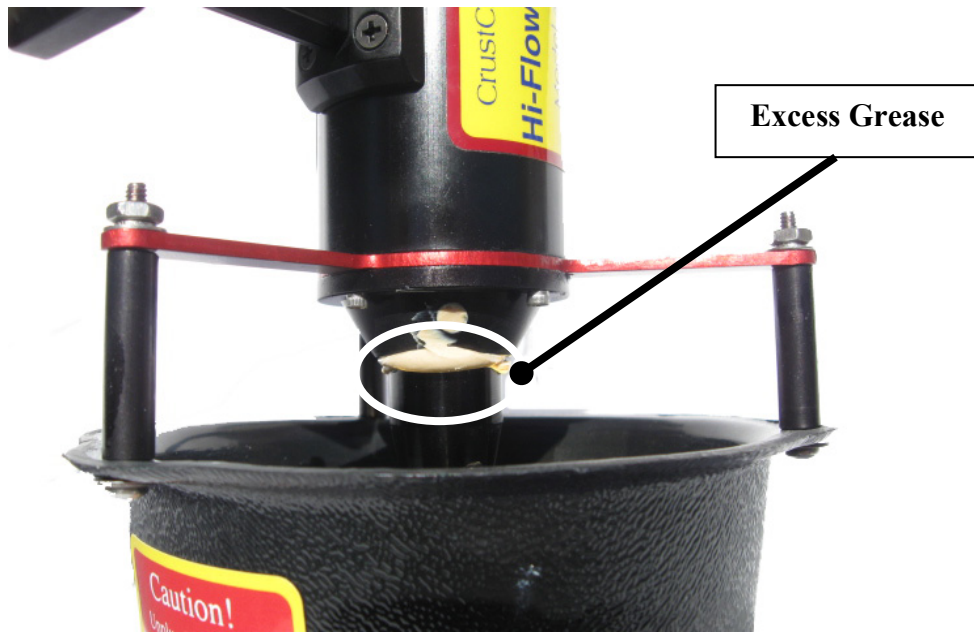

Figure 3 - Apply grease until excess grease emerges

Note: White Lithium grease is supplied to thruster orders of (3) units or more. If you are using your own grease, be sure to clean out the existing grease before applying a different type of marine grease or equivalent to the grease gallery as some grease can react to other grease types.

600HF Thruster Mounting Bracket

(Optional)



- Material – Machined 6061 T6 Aluminum
- Finish – Hard Anodized Black
- Mounting Screws – Quantity (6) - 4/40 (#4) – 1” (2.54cm)
- Thruster Mounting Screws – Quantity (4) - Stainless Steel 4/40 (#4) – 3/8” mounting screws
- Bracket / Kort Nozzle Clearance - .31” (7.8mm)

Mounting Hole Dimensions

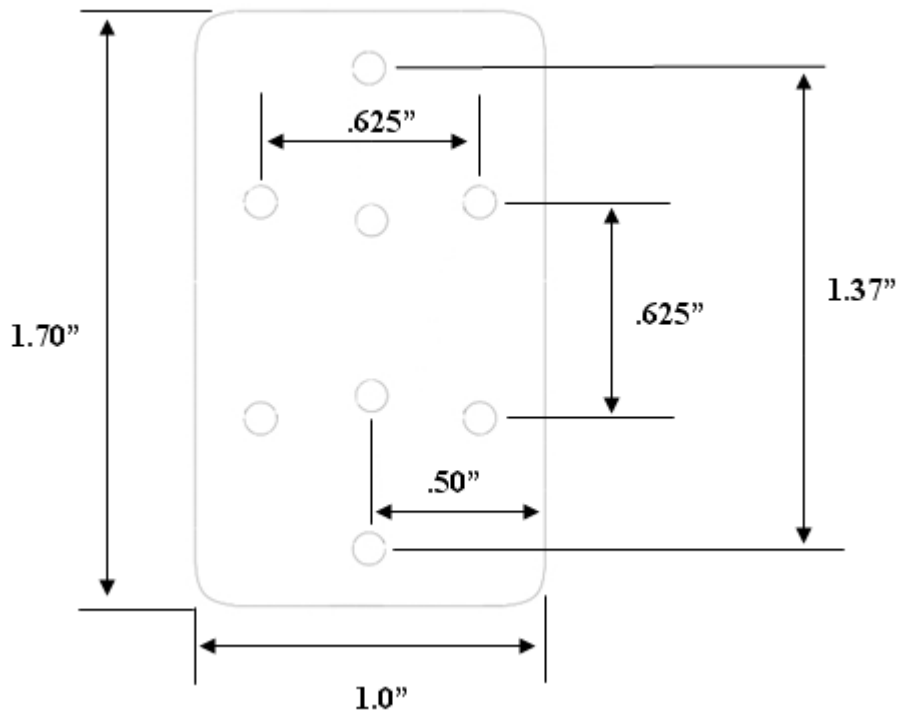



Figure 7 - 600HF Thruster with Mounting Bracket

- Use the supplied stainless steel, #4 (3/8") mounting screws to attach the thruster mounting bracket to the body of the thruster.
- Use a thread-locker type of sealant (like "Loctite or equivalent) for each of the (4) screws when mounting the bracket to the thruster.

Support

Support, should you need, it is available in 2 ways:

Forums - <http://forum.crustcrawler.com/phpBB3/index.php>

Phone – 480-577-5557

We strongly suggest questions dealing with control software, wiring and other related configuration information be posted on our forums. We use the forums to post code samples, wiring diagrams and pictures to help resolve customer questions quickly and efficiently.

Remember, we can't see your code or wiring over the phone, but we can see it using our forums! Please visit our web site frequently as we will be releasing more software and accessories in the coming months for our line of UROV and ROV products.

Repair

If your Hi-Flow Thruster is in need of repair, please call or e-mail CrustCrawler. We will provide you with information on how to get your Hi-Flow thruster repaired as soon as possible by our trained service technicians.

Note: Unless otherwise advised from CrustCrawler, NEVER try to repair the Hi-Flow Thruster yourself!

Phone- 480-577-5557

E-mail – Support@crustcrawler.com